



OurAir SQ 1750
Mobile Air
Purification System
for Virus-Free Air
Indoors

OurAir SQ 1750

Features & Functions

MOBILE AIR PURIFICATION SYSTEM

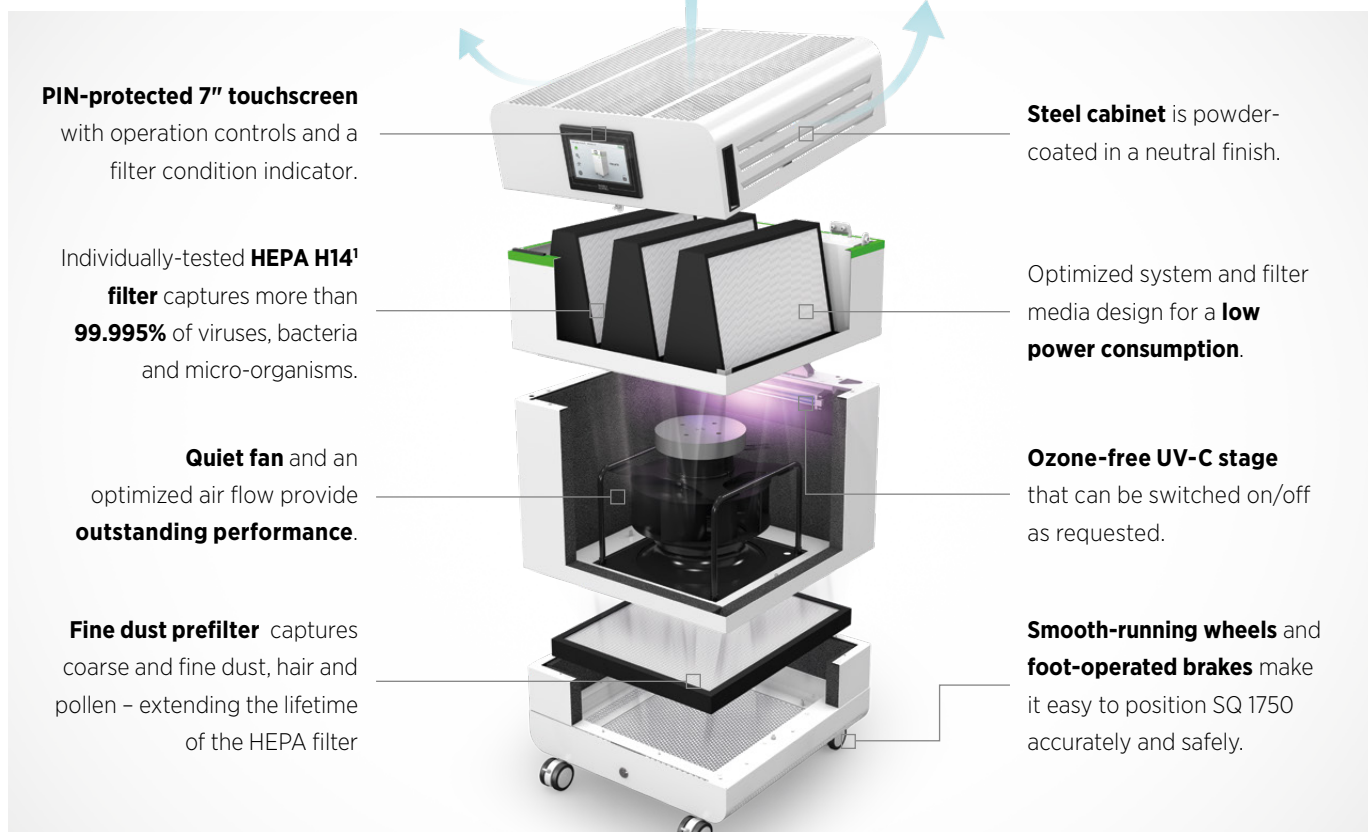

PIN-protected 7" touchscreen

with operation controls and a filter condition indicator.

Individually-tested **HEPA H14¹**

filter captures more than

99.995% of viruses, bacteria and micro-organisms.

Quiet fan and an

optimized air flow provide **outstanding performance.**

Fine dust prefilter captures

coarse and fine dust, hair and pollen – extending the lifetime of the HEPA filter

Steel cabinet is powder-coated in a neutral finish.

Optimized system and filter media design for a **low power consumption.**

Ozone-free UV-C stage

that can be switched on/off as requested.

Smooth-running wheels and

foot-operated brakes make it easy to position SQ 1750 accurately and safely.

OVERVIEW

OurAir SQ 1750 is a mobile air purification system that delivers virus-free air in practically any indoor environment. Its individually-tested H14 HEPA filter¹ captures more than 99.995% of viruses, bacteria and other micro-organisms – the same filtration technology that's used in many cleanrooms.

OurAir SQ 1750 is the perfect long-term solution to improving indoor air quality – bringing comfort to allergy sufferers, lowering air pollution and helping to reduce the number of sick days.

APPLICATIONS & USE

OurAir SQ 1750 has been designed to drastically reduce the virus load in buildings wherever people gather – from offices and classrooms to restaurants and gyms.

One OurAir SQ 1750 efficiently cleans the air in a room up to 140 m² in size. Multiple units can be used in conjunction for larger areas, or the OurAir SQ 2500 is an alternative solution for spaces up to 200 m².

SWITCHABLE UV-C STAGE

Viruses separated by the HEPA filter die off and remain inactive. If requested, an additional ozone-free UV-C stage can be activated.

Wavelengths below 240 nm are retained by specially-coated glass. The lamps are deactivated when the device is opened.

When using HEPA filters, UV-C lamps do not contribute to a further improvement in air quality and only sterilize the directly irradiated filter surface.

OurAir SQ 1750

Technical Information

PERFORMANCE DATA

TECHNICAL DATA	OURAIR SQ 1750
Dimensions (L x W x H)	0.65 x 0.65 x 1.25 m
Recommended Room Size (per unit)	Approx. 140 m ²
Net Weight (with filter)	85 kg
Cabinet Material	Powder-coated steel - 1.5 mm thick
Power Supply	230 V~
Power Consumption	75 W @ average operation speed (850 m ³ /h); 320 W @ maximum (1750 m ³ /h)
Circuit Breaker	Integrated - 4 amp
Air Flow Rate	400 - 1750 m ³ /h
Air Exchange Rate	- 5 times/hour (140 m ² room); - 6 times/hour (120 m ² room)
Filtration Efficiency	H14 ¹ (captures > 99.995% of viruses, bacteria and micro-organisms)
Pre-Filtration	ePM1 55%
Screen	PIN-protected 7" LCD touch screen
Options	Activated carbon prefilter

Subject to change without notice. ¹According to ISO 29463 & EN 1822.

SOUND OUTPUT

Noise level at various distances and directions with an air flow of 850 m³/h.

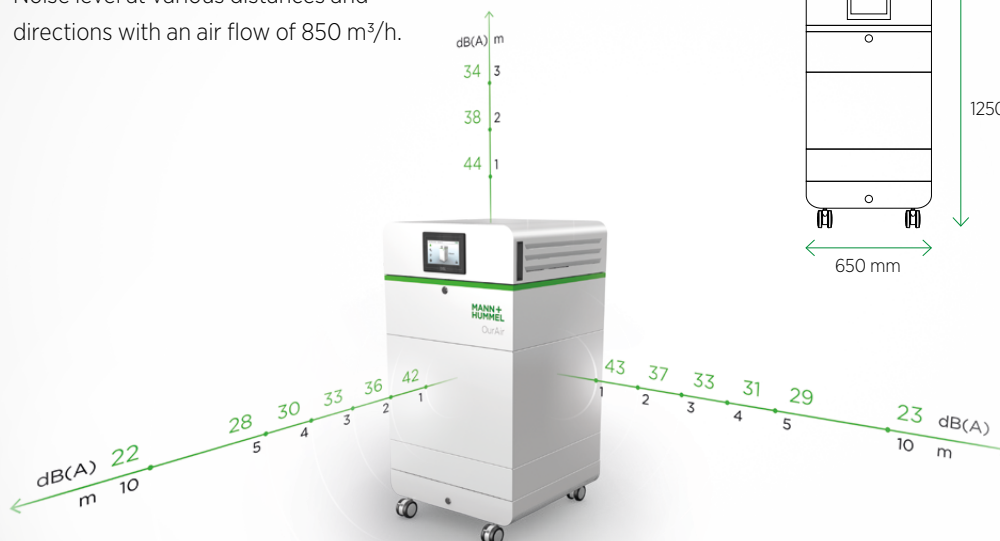

DIMENSIONS & LAYOUT

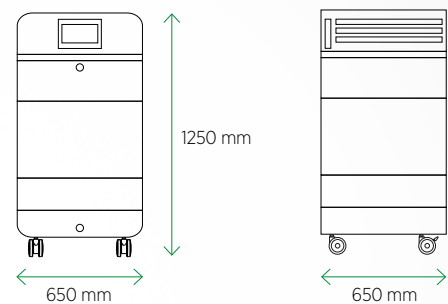



v8-0222 © MANN+HUMMEL GmbH